

Design and Analysis of a High-Precision Horizontal Machine Tools

Tzu-Chi Chan^{1,*}, Yu-Ping Hong¹, Jyun-Sian Yang¹, Jia-Hong Yu¹, Arindam Dutta¹ and Sabbella Veera Venkata Satyanarayana Reddy¹

¹Department of Mechanical and Computer-Aided Engineering, National Formosa University, Yunlin County 632, Taiwan, R.O.C.

Abstract: The horizontal machine tool has an automatic exchange table, which can be combined with a flexible manufacturing system for automatic processing and production. Therefore, it requires higher performance stability than other machines. This study analyzes the static and dynamic characteristics of a horizontal machine tool structure. The finite element analysis (FEA) method is generally used to analyze the whole machine structure and improve the deformation and resonance of the horizontal machine tool. In this study, FEA was applied to the design process of the machine tool, including static deformation analysis, modal analysis, transient analysis, and harmonic analysis of the machine. The deformation of the whole machine due to acceleration of gravity and cutting force was analyzed. The modal shapes generated by the first and third modes directly affected the machining process of the machine tool. To further analyze the influence of vibration signal processing on processing quality, transient response analysis was carried out on the effect of axial cutting force during machining. Spectrum analysis of the machine was also carried out. This study is expected to help the structural design of a horizontal machine tool to improve the dynamic characteristics and stability of the horizontal machining system.

Keywords: Horizontal machine tool, Modal analysis, Transient analysis, Harmonic analysis, Finite element analysis.

1. INTRODUCTION

Several studies on finite element analysis (FEA) methods for static and dynamic deformation analysis of manufacturing processes have been reported. Wu *et al.* [1] investigated the mechatronics modeling and forced vibration of a 2-DOF parallel manipulator in a 5-DOF hybrid machine tool. Li *et al.* [2] compared the dynamic performance of two 3-DOF parallel manipulators and proposed a novel optimization method for counterweight masses for the development of a new hybrid machine tool. Simon [3] applied the thermal analysis of lubrication to investigate the influence of the machine tool setting for pinion tooth finishing on the lubrication of gears. Ohta and Hayashi [4] studied the vibration of a linear-guideway-type recirculating linear ball bearing driven at constant velocity. Wu *et al.* [5] reported the stiffness of a 5-DOF hybrid machine tool with actuation redundancy. Whalley *et al.* [6] derived the X-Y axes and distributed-lumped model for a machine tool system. Model validations using measured results have also been presented. Gegg *et al.* [7] proposed a simplified mechanical model for a machine tool system. The states and domains were defined for the boundaries in this system. Ericson and Parker [8] applied experimental modal analysis to characterize the planar

dynamic behavior of two spur-planetary gears. Zhou *et al.* [9] demonstrated that because the machined surface is part of the cutter envelope surface generated by the cutter motion, it is necessary to calculate the envelope surface to obtain the geometric deviation. Fujishima *et al.* [10] studied sensing technologies for machine tools and attempted to improve cutting efficiency with this sensing system. Guo *et al.* [11] introduces a degradation analysis-based reliability assessment method for CNC machine tools under performance testing. Kim *et al.* [12] studied detection of chatter vibration that can compensate chatter vibration faster and produce processed goods with more precision by autonomous compensation. Hong *et al.* [13] Analysis of chatter is affected by the dynamic characteristics of machine tool structure.

Chan *et al.* [14, 15] discussed the structural characteristics of five-axis machine tools and modal testing methods to improve the static and dynamic characteristics of the entire machine, and optimize the base topology for weight reduction.

In this study, the FEA method is used to analyze the static and dynamic characteristics of the horizontal machine tool structure. The structural deformation and vibration of the machine tool are also analyzed.

The technical ability of the machine tool is considered an important indicator of an important indicator of industrialization. This study mainly analyzes the structural characteristics of the horizontal machine tool. The FEA method is used to analyze the static and

*Address correspondence to this author at the Department of Mechanical and Computer-Aided Engineering, National Formosa University, Yunlin County 632, Taiwan, R.O.C.; Tel:+886-5-6315329; Fax:+886-5-6315310; E-mail: tcchan@nfu.edu.tw

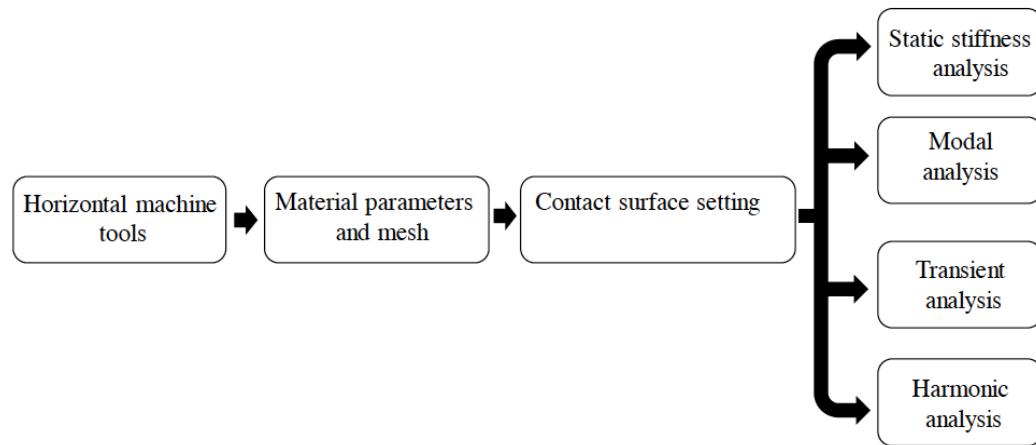

Figure 1: Flowchart of research.

dynamic characteristics of the whole machine structure, focusing on the structural deformation and vibration of the horizontal machine, which is then used as a reference index for the design and development of machine tools. The flowchart of this study is shown in Figure 1.

2. FINITE ELEMENT ANALYSIS MODEL

This study analyzes the structure of the horizontal machine tool by importing it into a Workbench CAD drawing file to establish the model and material properties. The materials used include cast steel and gray cast iron; the continuum was segmented by cutting the grid and nodes. For the element, the FE method was used in parameter-setting to solve for the behavior and characteristics of the simulated structure. FEA was performed using analysis software to explore the structural characteristics of the machine tool.

The model used in this study using CAD is shown in Figure 2.

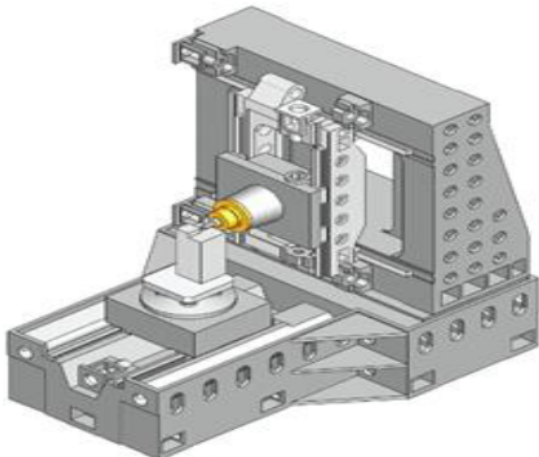

Figure 2: Horizontal machine tool CAD model.

2.1. Material Properties

The materials used in the horizontal machine tool include cast steel and gray cast iron. The material properties are listed in Table 1. The completed FE model is shown in Figure 3.

Table 1: Properties of Cast Steel Materials

Cast steel materials	
Density (kg/m ³)	7800
Young's modulus (Pa)	2.07×10^{11}
Poisson's ratio	0.28
Gray cast iron material properties	
Density (kg/m ³)	7200
Young's modulus (Pa)	1.24×10^{11}
Poisson's ratio	0.3

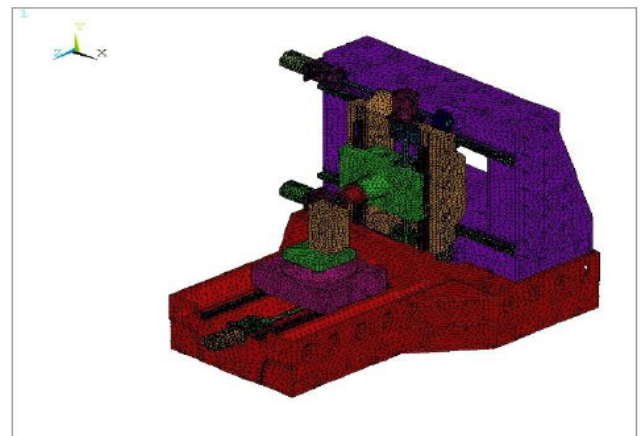

Figure 3: Finite element model of horizontal machine tool.

2.2. Finite Element Boundary Condition Setting

The machine tool has many combined interfaces. The linear motion uses a linear guideway. The contact between the slider and linear guideway was simulated by the spring, whose rigidity was set to 20000000 N/m. The fixing method of the relevant interface was based on the actual machine combination setup. The acceleration of gravity was 9.8 m/s^2 . The model is shown in Figure 4.

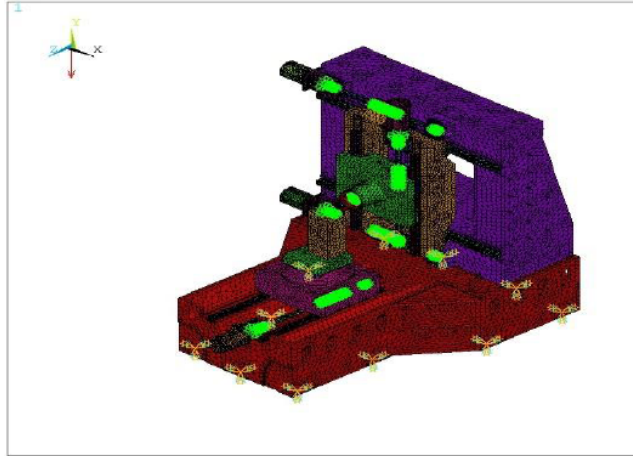

Figure 4: Horizontal machine tool boundary conditions.

3. FINITE STATIC STIFFNESS ANALYSIS

During the simulated machining process, the machine was subjected to a -500 N force along the Z-axis direction at the point of the tool tip. The analysis results show that large deformation occurred at the main shaft and rotating base; the maximum deformation amount was $30.9 \text{ }\mu\text{m}$. The static stiffness

analysis results are shown in Fig.5. The deformation of components is summarized in Table 2 while the static rigidity analysis results are shown in Table 3.

Table 2: The Deformation of Components

Structural Component	Total Deformation (μm)	Total Deformation (%)
Housing	10.4	33.0
Head	9.5	30.7
Saddle	6.0	19.4
Base	2.7	8.7
Index plate	2.9	9.2
Table	3.6	11.6
Entire machine structure	30.9	100

Table 3: Static Rigidity Analysis Results

Structural Component	Overall Stiffness (Kgf/ μm)
Housing	4.9
Head	5.4
Saddle	8.5
Base	18.9
Index plate	17.6
Table	14.2
Entire machine structure	1.7

4. MODAL ANALYSIS

The FE method was used to analyze the dynamic structure of the machine tool at the frequency range of

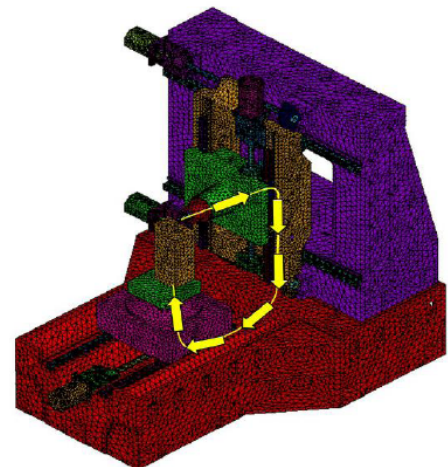
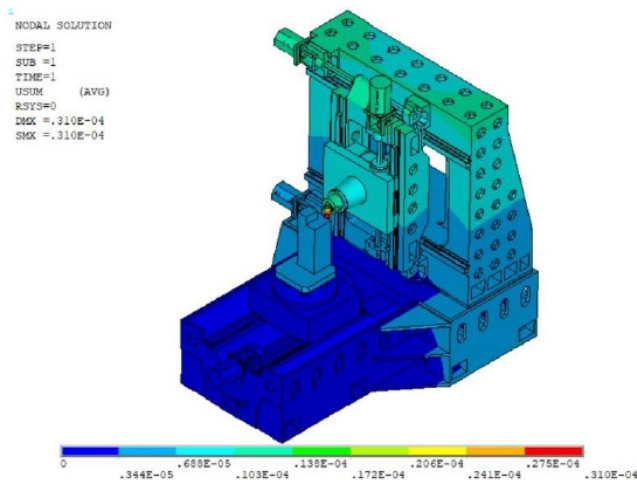

Figure 5: Static rigidity analysis and force flow of the horizontal machine tool.

Table 4: Modal Analysis and Mode Shape

	Modal Analysis	Description
Natural Frequency (Hz)	Mode Shape	
17.1		The main vibration mode of the first mode is the torsion of the column.
21.9		The main vibration mode of the second mode is the torsion of the column and saddle.
31.8		The main vibration mode of the third mode is torsion of the saddle, spindle, and column.

0–1000 Hz. The modal analysis results show that the vibration mode and natural frequency of the machine are 17.1 Hz, 21.9 Hz, and 31.8 Hz, respectively. The three-mode shapes are described in Table 4.

5. CUTTING TRANSIENT ANALYSIS

Transient analysis was conducted with impact force of 500 N, the fixed point was located at the base, and

the impact point of the impact force was at the tool tip, as shown in Figure 6. After the simulated cutting impact load was applied for 0.05 s, the force responds to the ureibration phenomenon within 5 s. From the results shown in Figure 7, the amplitude of the transient response along the X-axis direction of the tool nose point can be determined.

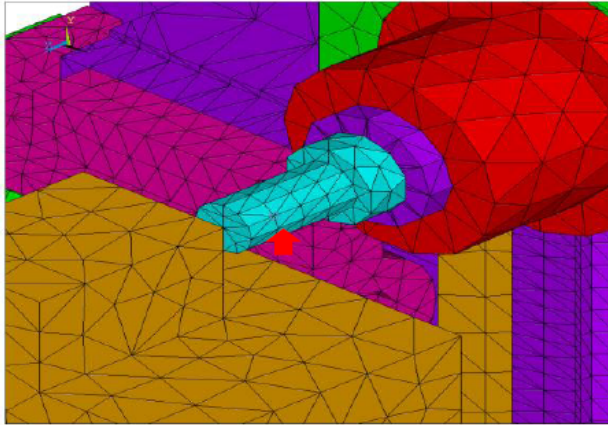

Figure 6: Cutting point of cutting force.

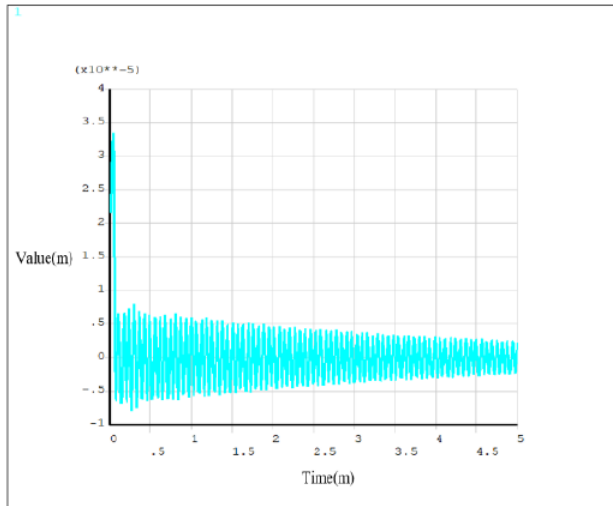

Figure 7: Transient response analysis in the X-axis direction.

6. CUTTING SPECTRUM ANALYSIS

The vibration frequency and amplitude of the horizontal machine tool along the X-, Y-, and Z-direction are shown in Figure 8–10, and the dynamic characteristics of tool machining were further analyzed. It was found that the cutting dynamic performance influenced the accuracy and efficiency of the cutting process.

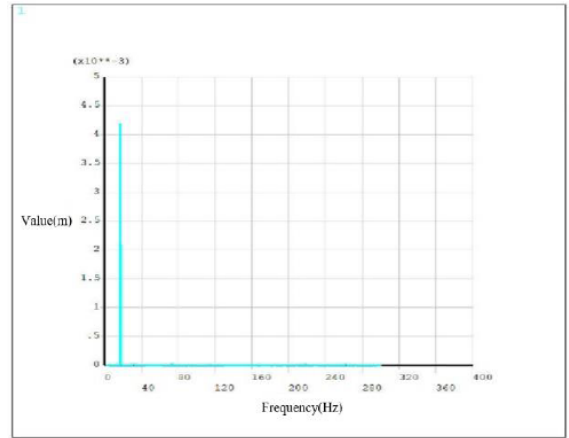

Figure 8: Cutting spectrum analysis in the X-direction.

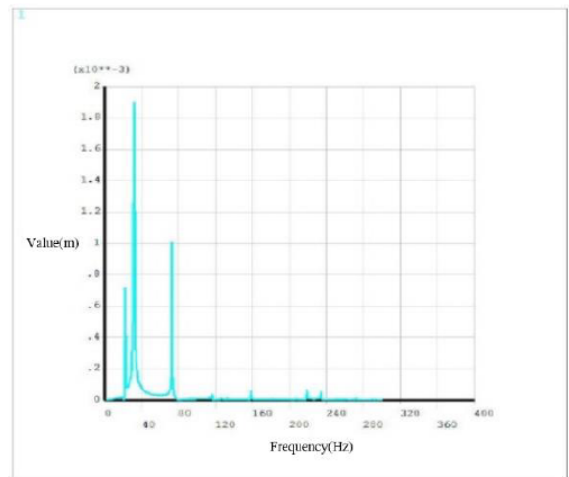

Figure 9: Cutting spectrum analysis in the Y-direction.

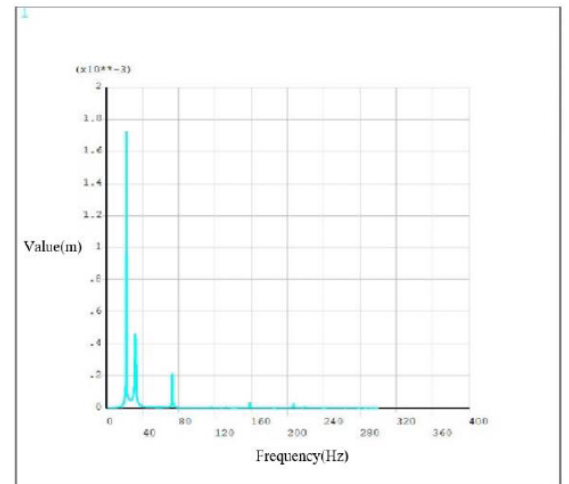

Figure 10: Cutting spectrum analysis in the Z-direction.

7. CONCLUSIONS

Owing to the rapid development of the machine tool industry, requirements such as machine tool accuracy, efficiency, shorter delivery time, machine planning and

structural configuration, and structural part design and analysis have become very important. Thus, further analysis of the static and dynamic cutting forces that cause machine structure deformation is required. Moreover, vibration affects the accuracy of the workpiece. This study used FEA to explore the static and dynamic characteristics of the horizontal machining system, and improvement of the whole machine structure, which can help improve related machine tool design technologies.

In this study, the actual machining conditions of the machine tool were simulated. Static stiffness analysis was carried out when -500 N was applied along the Z-axis direction at the tool tip point. The maximum deformation was 30.9 μ m. Static deformation analysis was used to determine the deformation and dynamic stiffness of each component. Vibration frequency and amplitude in the X-, Y-, and Z-directions were obtained to improve the static the static and dynamic characteristics of the overall machine.

ACKNOWLEDGEMENTS

The authors are greatly indebted to the National Science and Technology Council for supporting the research through contracts (Grant numbers:111-2221-E-150 -024 -MY2, 111-2622-E-1509) and the Precision Machinery Research and Development Center.

REFERENCES

- [1] Wu J, Yu G, Gao Y, and Wang LP. "Mechatronics Modeling and Vibration Analysis of a 2-DOF Parallel Manipulator in a 5-DOF Hybrid Machine Tool." *Mechanism and Machine Theory* 2018; 121: 1339-51. <https://doi.org/10.1016/j.mechmachtheory.2017.10.023>
- [2] Li YW, Wang JS, Liu XJ, and Wang LP. "Dynamic Performance Comparison and Counterweight Optimization of Two 3-DOF Parallel Manipulators for a New Hybrid Machine Tool." *Mechanism and Machine Theory* 2010; 45(11): 1668-80. <https://doi.org/10.1016/j.mechmachtheory.2010.06.009>
- [3] Simon V. "Influence of Machine Tool Setting Parameters on EHD Lubrication in Hypoid Gears." *Mechanism and Machine Theory* 2009; 44(5): 923-37. <https://doi.org/10.1016/j.mechmachtheory.2008.06.005>
- [4] Ohta H, and Hayashi E. "Vibration of Linear Guideway Type Recirculating Linear Ball Bearings." *J. Sound Vib.* 2000; 235: 847-61. <https://doi.org/10.1006/jsvi.2000.2950>
- [5] Wu J, Wang JS, Wang LP, Li T, and You Z. "Study on the Stiffness of a 5-DOF Hybrid Machine Tool with Actuation Redundancy." *Mechanism and Machine Theory* 2009; 44(2): 289-305. <https://doi.org/10.1016/j.mechmachtheory.2008.10.001>
- [6] Whalley R, Abdul-Ameer AA, and Ebrahimi KM. "The Axes Response and Resonance Identification for a Machine Tool." *Mechanism and Machine Theory* 2011; 46(8): 1171-92. <https://doi.org/10.1016/j.mechmachtheory.2011.02.012>
- [7] Ericson TM, and Parker RG. "Planetary Gear Modal Vibration Experiments and Correlation against Lumped-Parameter and Finite Element Models." *J. Sound Vib.* 2010; 50: 156-64.
- [8] Gegg BC, Suh SCS, and Luo ACJ. "Modeling and Theory of Intermittent Motions in a Machine Tool with a Friction Boundary." *Journal of Manufacturing Science and Engineering, Transactions of the ASME* 2010; 132(4): 0410011-9. <https://doi.org/10.1115/1.4001643>
- [9] Zhou YS, Chen ZC, and Yang XJ. "An Accurate, Efficient Envelope Approach to Modeling the Geometric Deviation of the Machined Surface for a Specific Five-Axis CNC Machine Tool." *International Journal of Machine Tools and Manufacture* 2015; 95: 67-77. <https://doi.org/10.1016/j.ijmachtools.2015.05.005>
- [10] Fujishima M, Ohno K, Nishikawa S, Nishimura K, Sakamoto M, Kawai K. Study Of sensing technologies for machine tools. *CIRP Journal of Manufacturing Science and Technology* 2016; 14: 71-75. <https://doi.org/10.1016/j.cirpj.2016.05.005>
- [11] Junyu Guo, Yan-Feng Li, Bo Zheng & Hong-Zhong Huang, Bayesian degradation assessment of CNC machine tools considering unit non-homogeneity, *Journal of Mechanical Science and Technology* 2018; 32: 2479-2485 <https://doi.org/10.1007/s12206-018-0505-1>
- [12] Dong-Hoon Kim, Jun-Yeob Song, Suk-Keun Cha & Hungsun Son, the development of embedded device to detect chatter vibration in machine tools and CNC-based autonomous compensation, *Journal of Mechanical Science and Technology* volume 25, (2011) Article number: 2623. <https://doi.org/10.1007/s12206-011-0737-9>
- [13] D. Hong, S. Kim, WC. Choi & JB. Song, Analysis of Machining Stability for a Parallel Machine Tool, *Mechanics Based Design of Structures and Machines*, 2003; 31(4): 509-528. <https://doi.org/10.1081/SME-120023169>
- [14] TC. Chan, Shang-Hong Wu, You-Ze Lin, Jenn-Yih Chen and BY. Lee, Structural Analysis and Dynamic Testing of Mini Five-Axis Machine Tools, The 15th IFToMM World Congress, Krakow, Poland, June 30 - July 4, 2019. https://doi.org/10.1007/978-3-030-20131-9_326
- [15] Tzu-Chi Chan, Yu-Ping Hong, Yu-Chuan Wang and Shang-Hung Wu, Optimization Design of the Composite Structure of Linear Motor Machine Tools, *Journal of Mechanics Engineering and Automation* 2019; 9: 219-224. <https://doi.org/10.17265/2159-5275/2019.07.001>

Received on 01-05-2023

Accepted on 29-06-2023

Published on 04-07-2023

DOI: <https://doi.org/10.31875/2409-9694.2023.10.04>

© 2023 Chan et al.; Licensee Zeal Press.

This is an open access article licensed under the terms of the Creative Commons Attribution Non-Commercial License (<http://creativecommons.org/licenses/by-nc/3.0/>), which permits unrestricted, non-commercial use, distribution and reproduction in any medium, provided the work is properly cited.