

Design and Experiment of a Reconfigurable Bypass Downlink Surface Equipment for Transmitting the Surface Information to Deep Well

Jiafeng Wu^{1,*}, Zaisheng Hao², Shujun Wang², Anni Wang², Guangze Li², Xiaocan Du², and Dongli Qin³

¹School of Petroleum Engineering, China University of Petroleum, Qingdao 266580, China

²Master, School of Petroleum Engineering, China University of Petroleum, Qingdao 266580, China

³College of Mechanical and Electronic Engineering, China University of Petroleum, Qingdao 266580, China

Abstract: In order to achieve the transmission of the control information from the surface to the downhole in the deep well during drilling, a design method of a new downlink surface equipment for generating negative pulse signals is presented in this paper. The equipment uses adjustable throttle control valve and pressure drop module (PDM) to realize bypass flow control. The PDM uses multistage variable nozzles to reduce drilling fluid pressure and meet drilling requirements under different pressure and flow rates. Design theory of the downlink surface equipment is established, and a specific design instance is given according to actual drilling conditions. Both laboratory and field experimental results verify the correctness of the proposed design method. The research results show that the design equipment can meet the needs of the transmission of the surface information, and the downlink transmission rate can reach at least one-bit data per 8 sec. The maximum pressure drop is realized by the PDM and the pressure drop at the control valve will be reduced according to drilling demand, the fluid velocity in the equipment is reduced as much as possible, the erosion of the drilling fluid to the equipment is reduced, and the service life can be improved effectively.

Keywords: Bypass downlink system, Negative pressure pulse, Pressure drop, Rotary steering system.

1. INTRODUCTION

With the further development of oil and gas exploration and development, the information interaction between the surface and downhole is one of the key technologies in future drilling. Technologies that transmit downhole information to the surface is called "uplink" [1-3], and the technique transmitting surface information to the downhole tool is called "downlink" [4]. Such as, during directional drilling, downlink communication can send a specific angle to the downhole tool to change the direction of the drill bit or the direction of the tool face.

The early downlink communication is to send the surface information by switching mud pump or changing the rotations speed of drillstring, and the downhole controller receives the downlink information by detecting the pressure variation or the rotation speed of drilling tool [5]. However, these early methods have long instruction time and low transmission rate, which will reduce drilling efficiency and the service life of the mud pump. Afterwards, some researchers put forward a bypass downlink method. In the method, a bypass pipeline into the mud tank is installed on the standpipe, and an on-off valve is mounted on the bypass pipeline. The pressure pulse of the drilling fluid is generated in the drillstring to realize the transmission

of downlink information through opening or closing of the valve. The downhole measurement equipment detects the flow and pressure signals of drilling fluid and realizes the reception of downlink information.

The description of the bypass downlink system mostly appears in some patents [6-8]. Finke *et al.* proposed a bypass downlink system, which sends control commander to downhole drilling tool through the on-off valve on the bypass pipeline, is composed of the downlink surface system, control system and downhole receiver [9]. Moriarty transmitted the surface information by changing the flow rate of the drilling fluid, and then used downhole turbine generator to receive downlink signals [10]. Treviranus *et al.* sent the downlink signal by changing the flow velocity of the drilling fluid in the wellbore, and the downhole sensor detects the parameters related to the flow change (such as voltage, etc.) to realize the reception of the downlink signal [11]. The downlink system proposed by Winnacker and Draeger mainly included a pneumatic switch valve and a pressure drop module, the pressure drop module has three drilling fluid outlets with different pressure levels, and each outlet has a large number of throttle orifice [12]. Different drilling fluid outlets can be selected according to different pump pressure, and the pressure drop of each outlet can be adjusted linearly, but the structure of the module is very complex.

The bypass downlink system has been commercialized. However, there is still a lack of research on design theory, and there are still some problems such as unknown bypass flow, low life of

Address correspondence to this article at School of Petroleum Engineering, China University of Petroleum, Qingdao 266580, China; Tel: +86-185-6150-9956; E-mail: wujiafeng@upc.edu.cn

equipment parts, very complex structure and so on. In this paper, the structure and design method of a new downlink surface device is presented, which can accurately control the discharge change of drilling fluid and reduce the erosion of the control valve under the high-pressure environment.

2. DESIGN METHOD OF THE DOWNLINK SURFACE EQUIPMENT

2.1. Bypass Downlink Communication Principle

During the drilling process, the mud is pumped into wellbore from mud tank, and flows through the standpipe, drilling hose, drillpipe and downhole turbine generator, drill bit and annulus (see Figure 1). In order to transmit control signals to rotary steerable drilling tool from the surface, a downlink surface system amounted on the standpipe periodically changes the discharge of the mud pumped into the drillpipe, and drilling fluid discharge pulses can be generated at downhole turbine generator. It can be obtained that the downlink information through acquiring and processing the output voltage of the generator. The principle of downlink communication with drilling fluid negative pulse is shown in Figure 1.

At the beginning of the downlink communication, the on-off valve in the downlink surface is closed. All the drilling fluid flows into the downhole through the standpipe and its discharge is equal to the pump discharge q_0 . During the downlink communication, the downlink information is encoded and converted into a sequence of "0" and "1". The valve remains open for the time t_0 when the bit "1" is sent, and the valve remains close for the time t_0 when the bit "0" is sent. When the valve is open, a small portion of drilling fluid flows into mud tank through the mud branch line, and the discharge of the drilling fluid into the downhole is reduced to q_1 , and when the valve is closed, the discharge of the drilling fluid into the downhole returns to q_0 . This creates a negative discharge pulse of the drilling fluid at the downhole. The turbine speed of turbine generator varies with the flow rates, which changes the rotor speed of the generator directly from ω_0 to ω_1 , and then the generator generates a voltage pulse signal u . The above process realizes the conversion of the drilling fluid negative flow pulse q to the voltage signal u . We can detect the voltage signal, demodulate the information for 0-1 encoding series, and decode the signal to realize the recovery of downlink information.

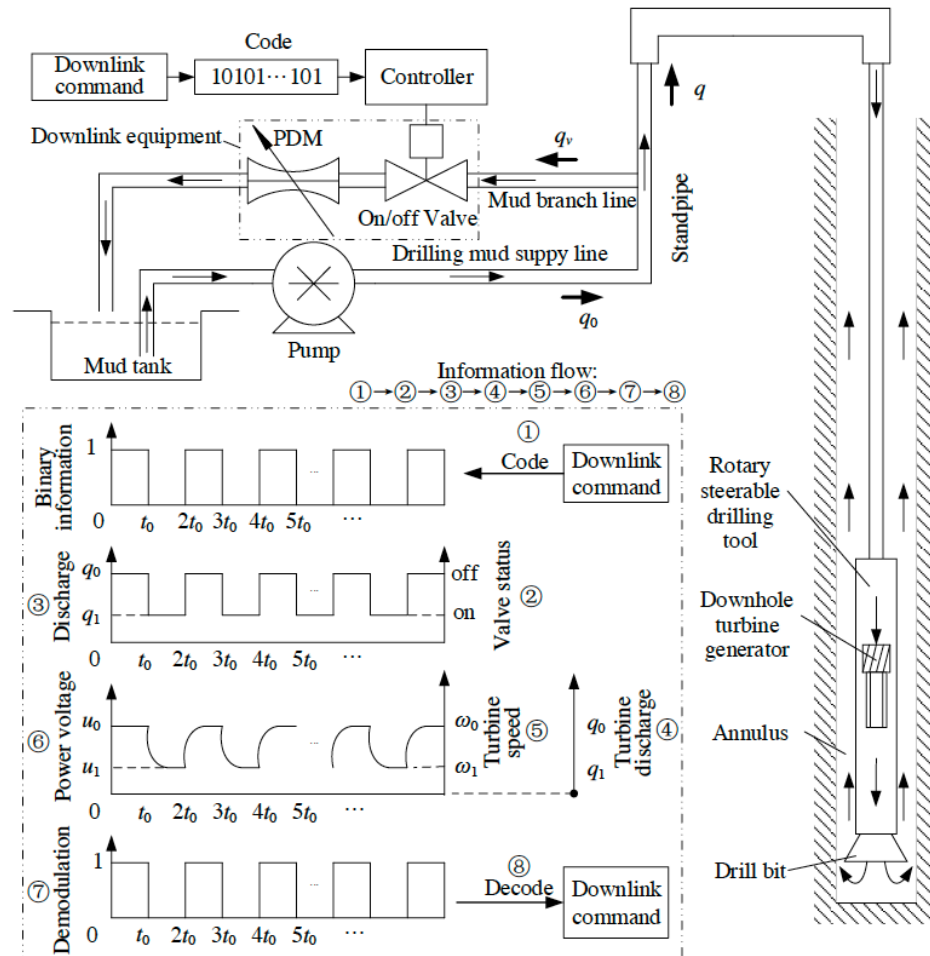

Figure 1: Schematic diagram of negative discharge pulse downlink method.

2.2. Design Theory of the Downlink Surface Equipment

As shown in Figure 2, the downlink surface system consists of Human Machine Interface (HMI), controller and downlink equipment based on the principle of bypass downlink communication. HMI is used to code the downlink command, the controller is used to control the downlink equipment, and the downlink equipment is used to generate the flow rate pulse. The discharge of drilling fluid into the downhole should be large enough to ensure reliable drilling operations, so the amplitude of the discharge pulses cannot be too large. However, discharge pulses with a small amplitude may not be received in the downhole. Therefore, the downlink equipment also has the function of precisely adjusting the flow rate of the drilling fluid into the drillpipe. In this paper, the downlink equipment is mainly divided into two modules: the on-off valve with a throttle function and pressure drop module (PDM). Several nozzles with different inner diameters are connected in series in the pressure drop module (see Figure 2).

The main function of the downlink surface equipment is used to adjust the bypass discharge flowing through the mud branch line precisely and regularly open or close the branch line. According to throttle principle, the standpipe pressure after opening the on-off valve can be described as Eq. (1).

$$p_0 = R_v q_v^2 = \frac{\rho}{2C_d^2 A^2} q_v^2 \quad (1)$$

where, p_0 is the standpipe pressure, Pa; R_v is a resistance coefficient flowing through the downlink equipment, $\text{Pa}\cdot\text{s}^2/\text{m}^6$; q_v is the bypass discharge, m^3/s ; ρ is mud density, kg/m^3 ; A is equivalent throttle area of the downlink equipment, m^2 ; C_d is flow coefficient flowing through the downlink equipment.

According to steady-state fluid dynamics in pipelines, the relationship between the pressure and discharge of the wellbore (including drillstring, drill bit, and annulus) can be formulated as Eq. (2).

$$p_0 = R_1 q_1^2 \quad (2)$$

where, R_1 is the equivalent resistance coefficient flowing through the wellbore, $\text{Pa}\cdot\text{s}^2/\text{m}^6$; q_1 is the discharge flowing into the wellbore when the on-off valve is open, m^3/s .

When the on-off valve is closed, the discharge flowing into the wellbore is the pump discharge q_0 . At the time, the standpipe pressure is set to P_0 . As the bypass discharge $q_v \ll q_0$, it is assumed that the equivalent resistance coefficient flowing through the wellbore is constant when the valve is open or closed, and yield as Eq. (3).

$$P_0 = R_1 q_0^2 \quad (3)$$

And because of $q_0 = q_1 + q_v$, the equivalent throttle area A can be derived as Eq. (4).

$$A = \frac{q_0 q_v}{C_d (q_0 - q_v)} \sqrt{\frac{\rho}{2P_0}} \quad (4)$$

Based on Eq. (4), the mud density ρ , pump discharge q_0 and standpipe pressure P_0 can be obtained by the sensors in the drilling site. The bypass flow q_v can be set according to actual drilling demand, and the flow coefficient C_d can be obtained from the equipment.

In order to adjust the amplitude of the negative flow pulse precisely, we need to ensure the accuracy of q_v . We may be able to use a flow meter for measuring the flow rate through the mud branch line, manually adjust the throttle area of the on-off valve so that the

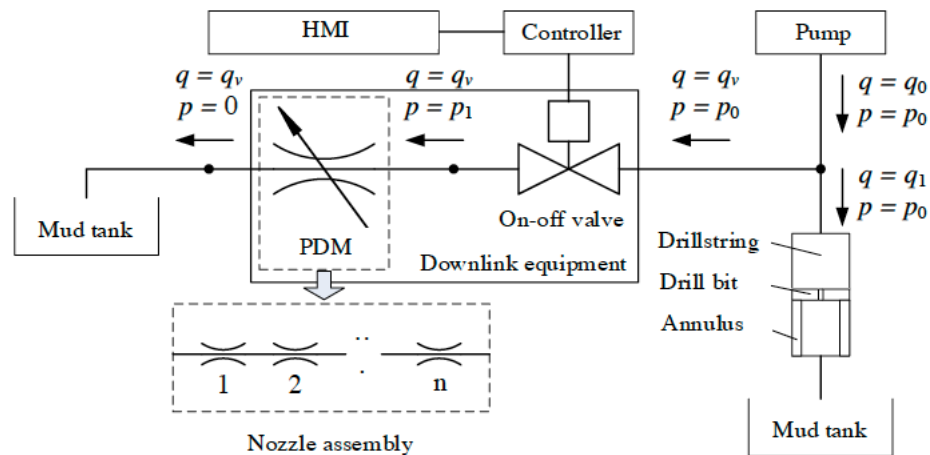

Figure 2: Schematic diagram of the reconfigurable downlink surface system.

flowmeter output value is equal to the bypass discharge. However, the solution has the following problems: One is the high cost of high-precision flowmeter; Second, the manual adjustment is very inconvenient; Third, the adjustment needs to be operated in high-pressure environment, it is unsafe; Fourth, the adjustable orifice is too small, the valve will be very severe erosion. Therefore, this needs to provide a design solution to the above problems.

As shown in Figure 2, the bypass discharge q_v corresponds to the equivalent throttle area A of the downlink equipment. If A can be accurately determined, q_v can also be accurately determined. The area A consists of the flow area A_v of the on-off valve and the equivalent flow area A_o of PDM. It is assumed that the discharge coefficient through the PDM is the same as that through the on-off valve, yield as Eq. (5) and Eq. (6).

$$p_1 = \frac{\rho}{2C_d^2 A_o^2} q_v^2 \quad (5)$$

$$p_0 - p_1 = \frac{\rho}{2C_d^2 A_v^2} q_v^2 \quad (6)$$

From Eq. (1), Eq. (5) and Eq. (6), we can obtain Eq. (7)

$$A = \frac{A_o A_v}{\sqrt{A_o^2 + A_v^2}} \quad (7)$$

In order to accommodate pump pressure and facilitate the installation of adjustment, the PDM is composed of several different sizes of throttle nozzles in this paper, which can be reconfigurable in series. The flow area A_o consisting of throttle nozzles is a constant value, and then the valve opening of the on-off valve is adjusted before the pump is started until the equivalent flow area of the downlink equipment reaches the predetermined value A .

It is assumed that there is N -type of nozzles, and the diameter of the i th nozzles is d_i , then A_o can be expressed as Eq. (8).

$$A_o = \frac{\pi}{4} \sqrt{\sum_{i=1}^N \frac{1}{d_i^4}} \quad (8)$$

Moreover, pressure drop from PDM can be described as Eq. (9).

$$p_1 = \frac{8\rho q_v^2}{\pi^2 C_d^2} \sum_{i=1}^N d_i^{-4} \quad (9)$$

where d_i is the diameter of the i th nozzle, N is the nozzle number.

According to the previous description, the adjustment procedure for the bypass discharge is as follows:

Step1: Input the standpipe pressure P_0 , pump discharge q_0 and mud density ρ before opening the on-off valve.

Step2: Set the bypass discharge q_v according to the turbine generator characteristics.

Step3: Calculate the equivalent flow area A of the downlink equipment according to Eq. (4).

Step4: Select the number of reasonable throttling nozzle n_i and diameter d_i .

Step5: Calculate the equivalent flow area A_o of the PDM according to Eq. (8).

Step5: Calculate the flow area of the on-off valve A_v according to Eq. (7).

Step6: Reconstruct the PDM and adjust the on-off valve according to A_o and A_v .

Because throttle nozzles have different combinations, the equivalent throttle area A_o of PDM will be different, and the different A_v values will be solved, there will be a variety of solutions. The on-off valve is a high cost, so the valve opening should be as large as possible to reduce erosion and improve the valve core life. Therefore, the nozzle combination can be calculated and chosen when A_v is the maximum value. Besides, the type and quantity of nozzles should be as little as possible to install and adjust conveniently.

3. DESIGN CASE FOR DOWNLINK EQUIPMENT

Design parameters of downlink equipment are shown in Table 1. According to the actual drilling operation requirements, the maximum pump discharge is set at 23L/s and the maximum pump pressure is 30MPa. The bypass flow should be determined according to the pump discharge and the turbine discharge. The working flow of the downhole turbine generator used for decoding is greater than 20L/s, and the minimum bypass discharge is set at 3L/s according to $q_0 = q_1 + q_v$. The smaller the pulse width of the negative flow pulse, the higher the transmission rate of the downstream communication, but the attenuation of the signal will be very serious. At the same time, because of the influence of channel reflection and transmission, it is very difficult to detect and deal with the downlink signals. Refer to the existing commercialized product, and the minimum pulse width is set to 8 seconds. According to the design

Table 1: Design Parameters

Maximum Pump Discharge (L/s)	Bypass Discharge (L/s)	Minimum Pulse Width (s)	Pump Pressure (MPa)
≥ 23	≥ 3	8	5~30

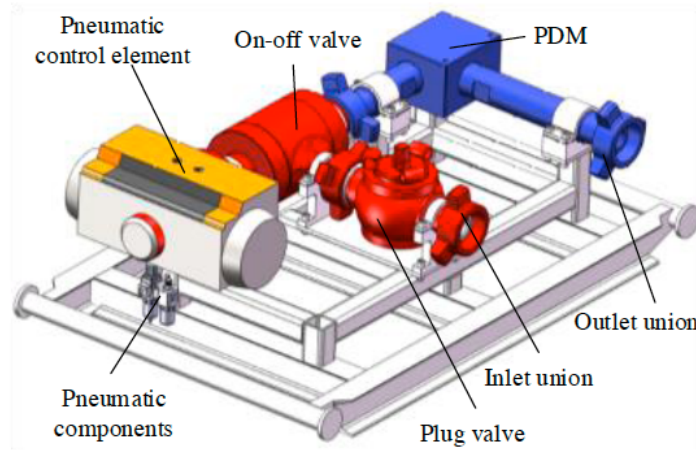

Figure 3: CAD model of the downlink surface equipment.

parameters in Table 1, the 3D model of the downlink surface equipment is shown in Figure 3.

The structure of the equipment is composed of an on-off valve, PDM, pneumatic control system, and plug valve etc. The on-off valve and plug valve, PDM are connected by unions. The on-off valve is used to turn on or off the bypass pipeline and has a certain throttling effect. The reconfigurable multistage nozzle structure is used in the PDM, which is mainly used to adjust the pressure drop of the downlink surface equipment. The PDM is installed in series with the control valve to ensure the precise flow out of the bypass line under a certain pump pressure. The plug valve is mainly used for safety protection. It is necessary to close the plug valve before changing the structure of the multistage nozzles at the drilling site. The pneumatic control system is used to open and close the on-off valves under the coding rules of the surface information, and the drilling fluid pulses corresponding to downlink information are generated. The key components of downlink surface equipment are the PDM and the on-off valve.

3.1. Design of the PDM

Too many nozzles in the PDM will make the installation and adjustment of the equipment cumbersome. There are three types of nozzles set up here, and a maximum of three nozzles is installed in the PDM. The diameters of these three types of nozzles are D_1 , D_2 and D_3 , respectively, $D_1 < D_2 < D_3$. It is known from the design principle that three nozzles with the diameter of D_1 in series can provide the maximum pressure drop. When the standpipe pressure is small

and the bypass flow is large, one nozzle with the diameter of D_3 can be selected.

The discharge coefficient of the nozzle has a great influence on the pressure drop P_1 and needs to be calibrated by the experiment. In the design process, assume that the flow coefficient is $C_d=0.8$ and the drilling fluid is pure water with a density of $\rho=1000\text{kg/m}^3$. According to the design parameters in Table 1 and Eq. (9), and the minimum nozzle diameter D_1 is 5.8mm when the maximum pump pressure is 30MPa and the bypass flow is 3L/s. When the minimum pump pressure is 5MPa and the bypass flow rate is 7L/s, and the maximum nozzle diameter D_3 is 10.5mm. Therefore, choose $D_1=6\text{mm}$, $D_2=8\text{mm}$ and $D_3=10\text{mm}$ to design the PDM. According to the sizes of the above nozzles, when the bypass flow is 3L/s-7L/s, the pressure drop produced by a single nozzle is shown in Figure 4.

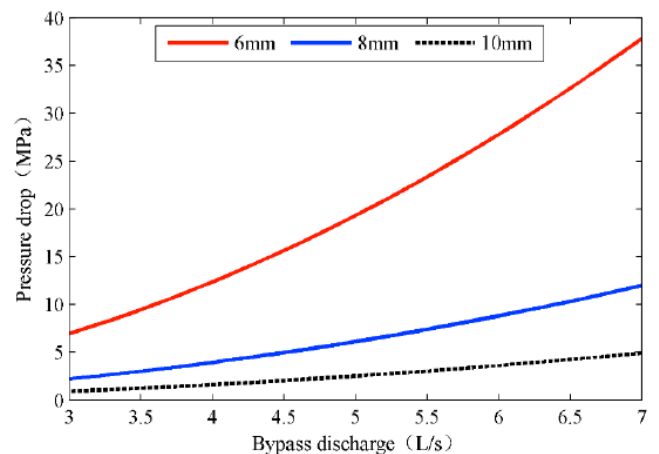

Figure 4: Pressure drop with a single nozzle.

It can be seen from the Figure that the pressure drop of 5MPa-30MPa can be covered by a single nozzle when the nozzle of the three sizes is selected. However, in the design concept of reconfigurable PDM, the combination of multistage nozzle can effectively reduce the flow velocity through the nozzle, reduce the erosion of the jet to the equipment, and improve the service life of the equipment. Therefore, in order to minimize the nozzle jet velocity, the nozzle assembly can be optimized to achieve the optimal design of the PDM.

In the field application process, the reasonable turbine flow is first given according to the requirements of the downhole turbine generator, and then the bypass flow is determined according to the flow rate of the pump. Finally, the nozzle combination is selected according to the bypass flow. According to Eq. (9), the equivalent nozzle diameter of any nozzle combination d_0 can be described as Eq. (10).

$$d_0 = \left(\sum_{i=1}^N d_i^{-4} \right)^{-1/4} \quad (10)$$

where $1 \leq N \leq 3$, $d_i = D_1, D_2$ or D_3 .

There are 19 different combinations (or equivalent diameters) of three types of nozzles, as shown in Figure 5. When selecting the nozzle combination, the equivalent throttle area A for the downlink surface equipment is solved first by Eq. (8), and then the equivalent diameter d_0 can be obtained. Then locate the equivalent diameter d_0 in Figure 5, the combinations with smaller equivalent nozzle diameter is selected. Finally, we can calculate the throttling area A_v of the on-off valve according to the algorithm in the previous section. The designed PDM model is shown in Figure 6, the nozzle assembly is placed in a structure that can be easily disassembled, and the structure can be disassembled and installed flexibly according to the actual requirement.

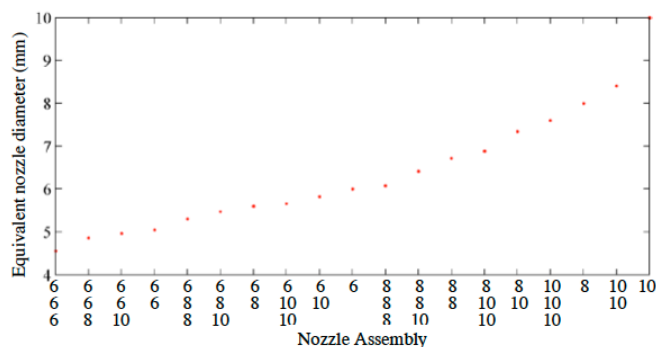

Figure 5: Equivalent hydraulic diameter of nozzle assemblies.

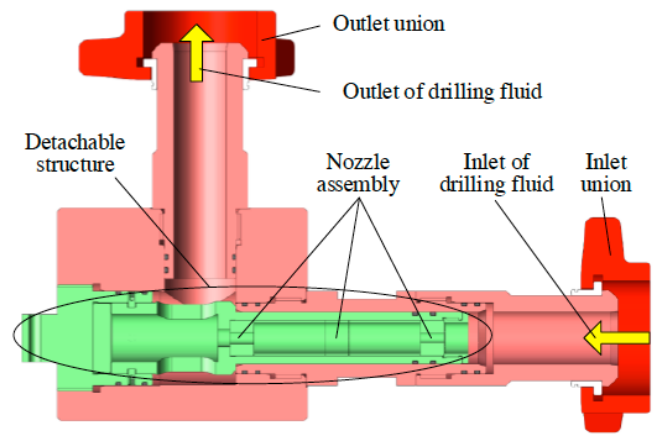

Figure 6: Structure model of Pressure drop module.

3.2. Design of the on-Off Valve

When considering the pressure and erosion resistance, it is necessary to minimize the opening and closing time of valves. In addition, the on-off valve can accurately adjust the pressure in a small range, so it is necessary to adjust the opening area of the valve accurately. Therefore, an on-off valve control valve that can meet the requirements of precise throttling and fast switching needs to be designed according to the drilling condition.

Because of the great resistance of closing valve or opening valve in high-pressure and high-flow environment, the existing valve cannot meet the requirement of quick opening and closing, so a new type of valve spool is designed in this paper, and its structure principle is shown in Figure 7. The spool is mainly composed of a rotating shaft, spring, rotor and stator. Three compression springs are fixed on the end of the rotating shaft. The spring thrust tightly fits the rotor to the stator, and there are planar flow holes on the rotor and stator. The rotating shaft drives the rotor to rotate, thereby achieving the opening and closing of the valve. When the valve is opened, the flow passage of the stator and rotor is partly superposed. The high-pressure drilling fluid flows from the rotor to the stator, which forming high pressure on one side of the rotor and forming a low pressure on the side of the stator, and this pressure difference will close the rotor tightly to the stator. When the valve is closed, the end faces between the rotor and the stator are tightly attached, and the high-pressure difference makes the seal between the rotor and the rotor closer. Because the movement of the valve is perpendicular to the flow direction of the drilling fluid, the required driving torque is small, and the valve can be quickly opened and closed to meet the requirements of the fast opening and closing of the on-off valve in the downlink surface equipment.

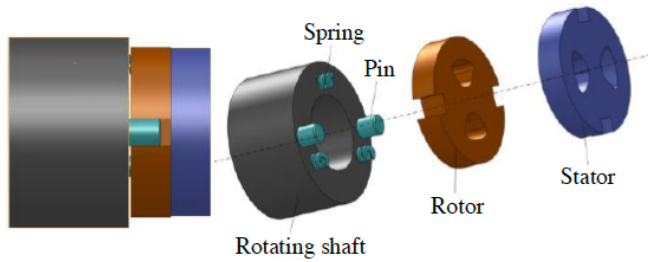

Figure 7: The structure principle of the on-off valve.

In order to facilitate the adjustment of the opening area of the on-off valve, the valve orifice is designed to be fan-shaped. As shown in Figure 8, the rotor and stator are composed of two fan-shaped orifices with the same shape.

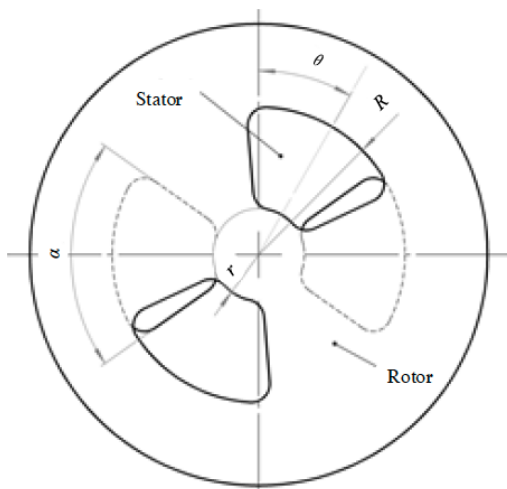

Figure 8: The valve orifice of the on-off valve.

The relationship between the flow area A of the on-off valve and the rotation angle θ of the drive shaft can be expressed as Eq. (11):

$$A = \begin{cases} 0 & , \theta \in [0, \pi/2 - \alpha] \\ 2(\alpha + \theta - \pi/2)(R^2 - r^2) & , \theta \in [\pi/2 - \alpha, \pi/2] \end{cases} \quad (11)$$

where α is the fan-shaped angle of the valve orifice, θ is the rotating angle, R is the outer radius of the valve orifice, and r is the inner radius of the valve orifice.

According to the Eq. (11), the flow area is approximately proportional to the rotation angle, so the flow area of the valve can be determined by adjusting the rotation angle of the rotor. Besides, the pneumatic actuator is chosen as the power output with a simple and reliable structure and safety. Because the required driving force of the designed valve is small, and this pneumatic actuator can meet the demand of downlink equipment. Therefore, the designed structure of the on-off valve is shown in Figure 9.

4. EXPERIMENT

According to the design parameters of Table 1, the downlink surface equipment developed by the above design theory is shown in Figure 10. Under the laboratory experiment and the field experiment, control precision of the bypass flow of the downlink equipment is tested, and the correctness and effectiveness of the design method of the downlink surface equipment are verified.

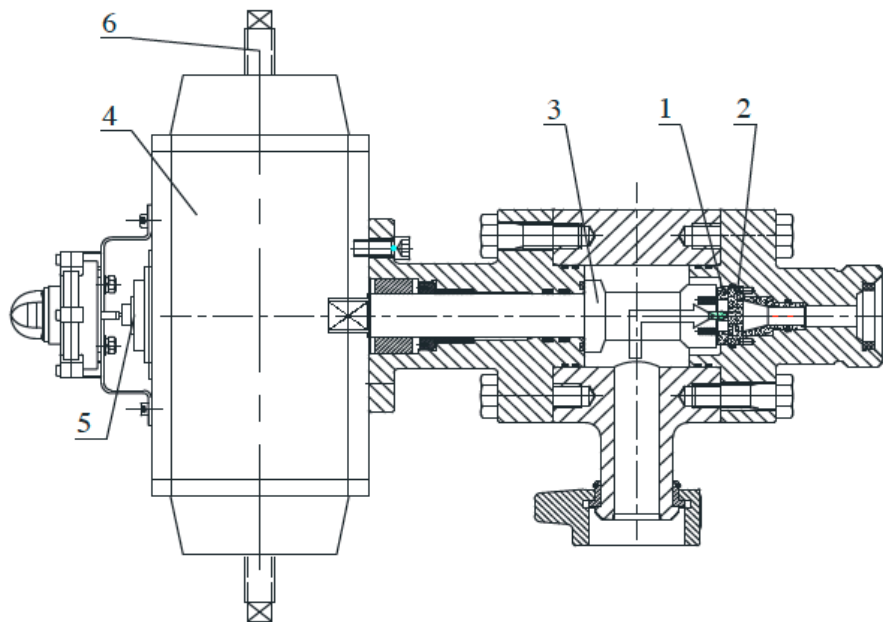

1-Rotor ; 2-Stator ; 3-Drive shaft ; 4-Actuator ; 5-Dial scale ; 6- Locking screw

Figure 9: The structure of the on-off valve.

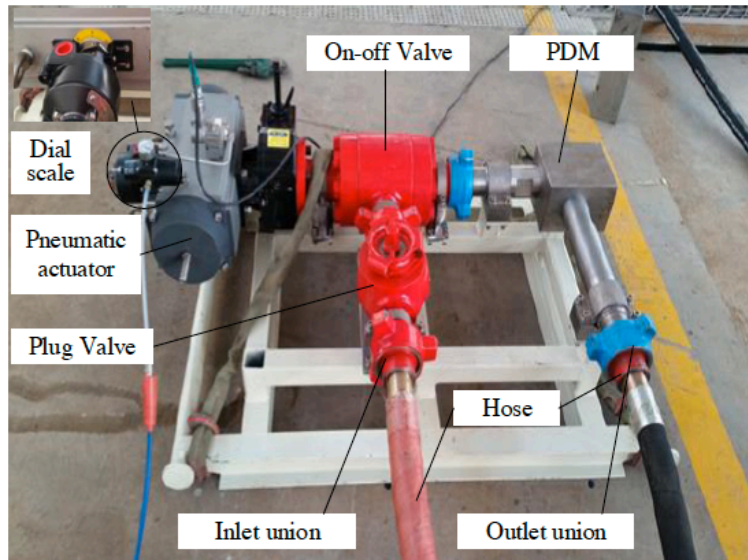

Figure 10: The prototype of downlink surface equipment.

4.1. Laboratory Experiment

In order to verify the feasibility of the developed downlink equipment, an experimental system has been built. The system consists of a drilling pump, water tank, throttle valve, hydraulic test equipment, three-way piece, the designed downlink equipment and rotary steering system equipped with a downhole turbine generator, as shown in Figure 11. The drilling pump is connected to the three-way piece through the high-pressure hose, and the other ends of the three-way piece are connected by the inlet of the downlink equipment and the rotary steerable drilling tool, respectively. The rotary steerable tool is installed on the hydraulic test equipment. The outlet of the downlink surface equipment is directly connected to the water tank through the hose. The experimental system allows the maximum pump pressure of 10MPa and the

flow rate of 35L/s to meet the testing requirements of the downlink surface equipment.

Hydraulic test equipment is shown in Figure 12. The equipment is used to detect the flow rate and pressure of drilling fluid, test the steering ability and precision of the rotary steering tool, and determine the working state and performance of the rotary steering tool. In this paper, a turbine generator in rotary steerable tool is used to receive downlink information. The information of the flow rate is collected as the voltage signal and stored in the memory of the tool.

In the experiment, the pump displacement is 30L/s when the pump pressure is 6MPa. If the bypass flow is 3L/s, the nozzle assembly of "10mm-10mm" can be selected for downlink surface equipment according to the above design theory. The control accuracy of bypass flow of the downlink surface equipment is

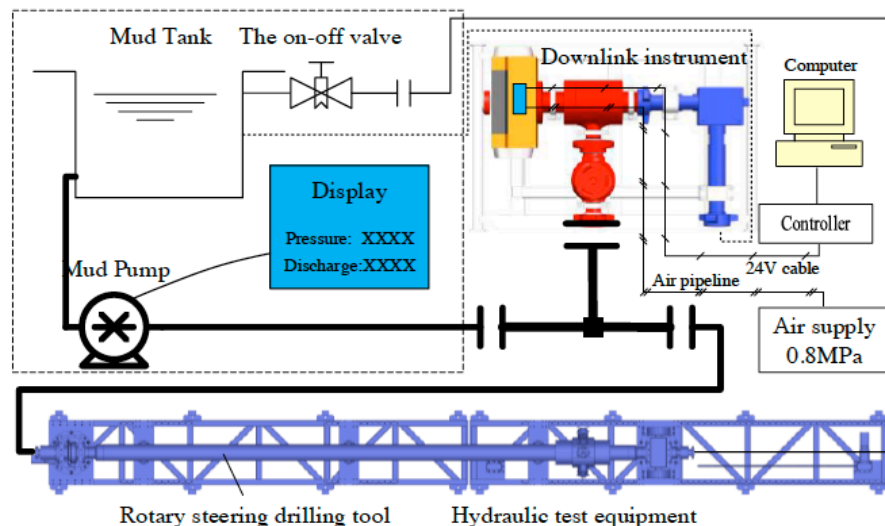

Figure 11: Laboratory experiment system.

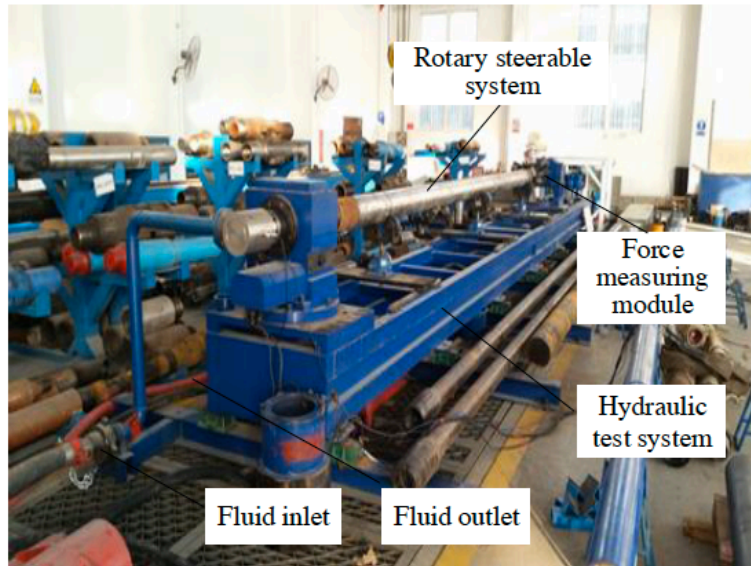

Figure 12: Hydraulic test equipment for RSS.

Table 2: Experiment Results of the Bypass Discharge

Items	Pump discharge (L/s)	Back-flow discharge (L/s)	Bypass discharge (L/s)	Pump pressure before valve opening (MPa)	Pump pressure after valve opening (MPa)
1	28.3	25.7	2.6	5.5	4.32
2	30	26.8	3.2	6	4.72
3	31.3	27.9	3.4	6.57	5.15

analyzed below. When the pump discharge reaches the set value, the pump pressure and the pump discharge are recorded. Then the pneumatic control valve is opened, the discharge flowing into the water tank and the pump pressure after the valve opening are recorded. The test results are given in Table 2, and the bypass discharge can be obtained by the difference between the pump discharge and the back-flow discharge. The results demonstrate that the higher the pump pressure, the greater the bypass discharge. When the pump discharge is 30L/s, the downlink surface equipment is used to realize the bypass discharge of 3.2L/s, and this is 6.7% different from the preset value of 3L/s. The experimental results verify the correctness of the design theory of downlink surface equipment.

First, set the pulse interval to 10 seconds, the synchronous header to “10s-10s-25s-10s”, and send the first downlink binary code “1001001000111”. Then set the pulse interval time to 8 second, the synchronization head is set to “8s-8s-20s-8s”, send the second downlink information binary code “101000100000110”. The waveform of the output voltage of the downhole turbine generator collected is shown in the grey line in Figure 13. Because the signal noise is very strong, the frequency of the downlink

signal is very low, and the FIR low pass filter is used to reduce the noise. The cut-off frequency of the low pass filter is set to 0.5Hz, the filter order is set to 200, and the filtered result is shown in the red line in Figure 13.

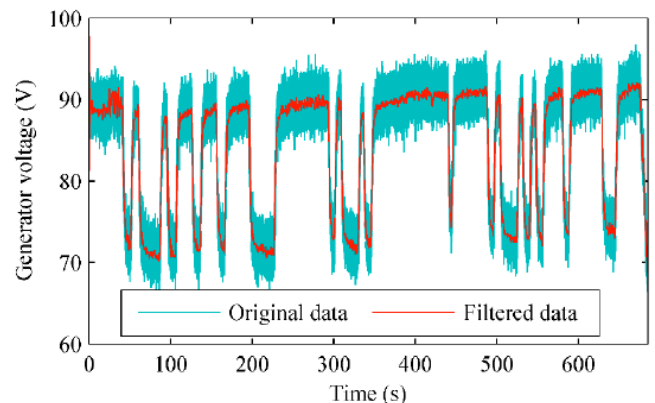

Figure 13: The received downlink signal in the laboratory experiment.

The first downlink information is identified, and the waveform shown in Figure 14 is obtained. The corresponding decoding result is "1001001000111", which is the same as the original encoding data. It can be seen from Figure 14 that the discharge through the generator varies rapidly after opening or closing the valve in the downlink surface equipment, and can

reach a steady state until fully open or completely shut down for some time. The second downlink information is identified, and the waveform is shown in Figure 15. The corresponding decoding result is "101000100000110", which is also the same as the original encoding data. The laboratory experiment shows that the designed equipment can reliably realize the downlink telemetry under the pulse width of 8 seconds.

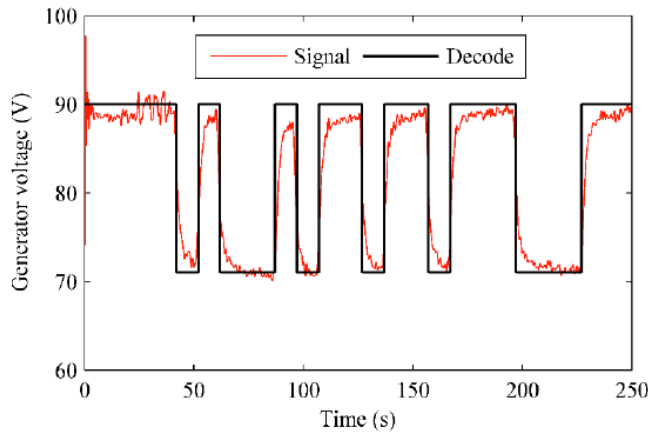

Figure 14: Decoding of downlink information under the pulse width of 10 seconds.

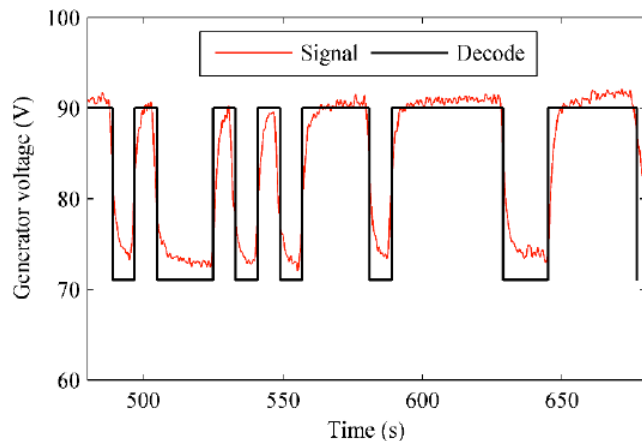

Figure 15: Decoding of downlink information under the pulse width of 8 seconds.

4.2. Field Experiment

In order to verify the effectiveness of the designed equipment, a field experiment was carried out. In the field experiment, when the well depth is 1500m, stop drilling and prepare to send downlink information. The downlink surface equipment in the drilling field is shown in Figure 16. According to the drilling conditions, the pump pressure is 13MPa, the drilling fluid discharge is 33L/s, the drilling fluid density is 1050kg/m³, the bypass discharge is set to 4L/s, and the nozzle assembly "10mm-10mm" of the downlink equipment is selected, and the rotation angle of the on-off valve is set to 80 degrees.



Figure 16: Downlink surface equipment in the field experiment.

First, in order to analyze the duration of the falling edge or rising edge of the discharge pulse signal after the opening or closing, a pulse instruction with the pulse width of 80s-40s-60s is sent to the downhole, and the signal received by a downhole turbogenerator is shown in Figure 17. The original signal in Figure 17 is partly high-frequency noise, which is caused by flow fluctuation and electronic noise, a FIR lowpass filter with the filter order of 200 and the cut-off frequency is 0.5Hz is used to remove the noise, the processing results are shown in the red line in Figure 16. It can be seen from the figure that the flow rate in the wellbore will be stabilized after the control valve is opened or closed 15 seconds. So, if the pulse width of the control valve is less than 15s, the flow rate will rise again (or descend) when the flow does not fall (or rise) to the stable value, which will result in the amplitude of the generated flow pulse wave less than the difference between the maximum steady discharge and the minimum steady discharge. Therefore, the smaller the pulse width of the selected signal the greater the transmission rate of the downlink communication, but the smaller the intensity of the downhole signal.

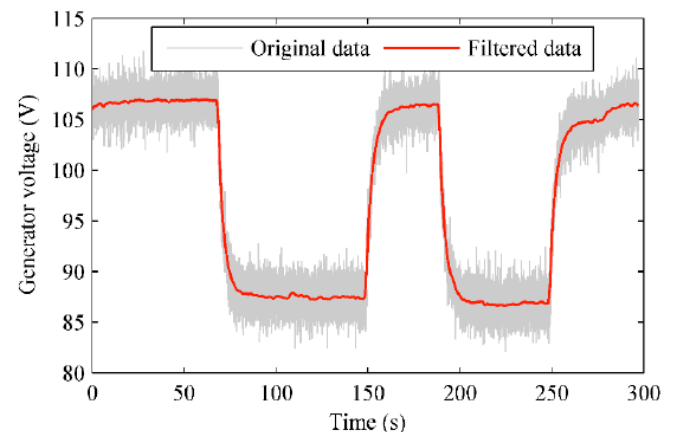

Figure 17: Received signal of the pulse width of 80s-40s-60s.

Then, the pulse width is set to 8 seconds, the synchronization head is set to "8s-8s-20s-8s" and a binary signal "1100-00001011-01110111-0101" is sent down to the downhole. In the signal, the first 3 bits represent the steering mode, the fourth bit is the checksum of the first 3 bits, the fifth to twelfth bits indicate the inclination angle, the thirteenth to twentieth position is the azimuth angle, and the last 4 bits are represented as check bits. That means that the information with the inclination angle of 5.5° and azimuth angle of 178.5° is sent to the downhole, the signal collected by the downhole turbine generator is shown in Figure 18.

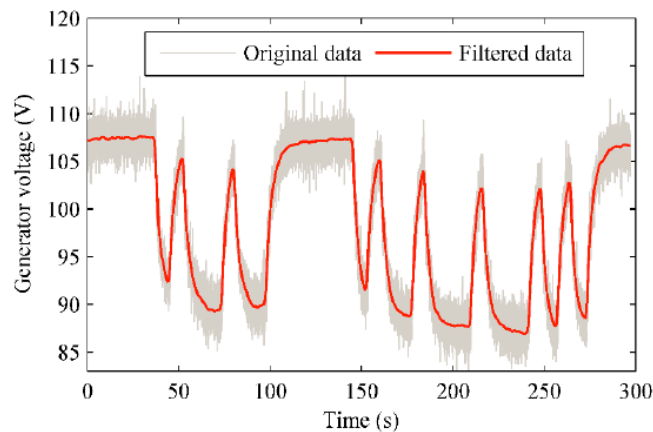

Figure 18: Drilling direction information received by downhole turbine generator.

It can be seen from the figure that the signal difference between the received signal and the rectangular pulse is greater because of the signal attenuation, but the signal characteristics are obvious. After synchronizing the signal with the synchronous head "8s-8s-20s-8s", the data segment is decoded, and the decoding result is "110000001011 011101110101". The decoding result is the same as the downlink information sent from the surface, which indicates that the designed equipment can realize the transmission of the surface control information to the downhole tool.

It can be seen from Figure 18 that the pulse amplitude generated with the pulse width of 8 seconds is small. However, the signal characteristics are still obvious, so it is possible to select the smaller pulse width to improve the downlink transmission rate in the well with 1500m depth using the designed downlink surface equipment. Therefore, the experiment results show that the designed equipment can realize the rapid transmission of the downlink signal to meet the actual engineering requirements, and verifies that the proposed design theory of the downlink surface equipment is correct and feasible.

5. CONCLUSION

A design method is presented to design the bypass downlink equipment that is used to generate negative pulse signals for sending the downlink information to the downhole. The crucial idea of this method is that the design theory is proposed for a new structure of downlink surface equipment based on the throttle principle and fluid mechanics. The equipment structure is mainly composed of an on-off valve and a reconfigurable PDM. Detailed design methods of the on-off valve and PDM are given in this paper.

In the presented method, a detailed design case is given, and the designed downlink surface equipment has been used in the laboratory experiment and field experiment to verify the correctness and feasibility of the proposed design method and design theory. According to the experiment results, the following conclusion can be drawn. The precision of the bypass discharge can be controlled about 6.7%. The flow rate in the wellbore will be stabilized after opening or closing the control valve for about 15 seconds, the designed downlink surface equipment can achieve reliable data transmission with 1/8 bit/s, and the designed equipment can realize the rapid transmission of the downlink signal to meet the actual engineering requirements. The research results also show that the smaller the pulse width of the selected signal the greater the transmission rate of the downlink communication, but the smaller the intensity of the downhole signal.

ACKNOWLEDGEMENTS

We would like to thank the anonymous reviewers for their valuable suggestions and corrections. This research was supported by the National Natural Science Foundation of China (Grant No. 51604296).

Nomenclature

p_0	standpipe pressure, Pa
R_v	resistance coefficient flowing through downlink equipment, $\text{Pa}\cdot\text{s}^2/\text{m}^6$
q_0, q_1, q_v	pump discharge, turbine discharge, bypass discharge, m^3/s
ρ	mud density, kg/m^3
A	equivalent throttle area of the downlink equipment, m^2
A_v	the equivalent flow area of the on-off valve, m^2
A_o	the equivalent flow area of PDM, m^2
C_d	flow coefficient flowing through downlink equipment, -
R_1	equivalent resistance coefficient flowing through the wellbore, $\text{Pa}\cdot\text{s}^2/\text{m}^6$

d_i	diameter of the i th nozzle, $i=1, \dots, N$, m
\bar{d}_i	equivalent nozzle diameter of any nozzle combination, m
D_1, D_2, D_3	diameters of three types of nozzles, m
N	nozzle number, -
α	fan-shaped angle of the designed valve orifice, °
θ	rotation angle, °
R	Outer diameter of valve orifice, m
r	Inner diameter of valve orifice, m
HMI	Human Machine Interface
PDM	pressure drop module

REFERENCES

- [1] Caruzo A, Hutin R, Reyes S, *et al* Advanced design and execution techniques for delivering high data rate MWD telemetry for ultradeep wells. OTC Arctic Technology Conference. 2012. <https://doi.org/10.4043/23749-MS>
- [2] Emmerich W, Brahim IB, Akimov O, Greten A. Improved high-speed mud pulse telemetry performance under harsh conditions. Offshore Technology Conference Asia. 2016. <https://doi.org/10.4043/26765-MS>
- [3] Wu J, Wang R, Zhang R, *et al.* Propagation model with multi-boundary conditions for periodic mud pressure wave in long wellbore. *Applied Mathematical Modelling*. 2015. 39(23–24): 7643-7656. <https://doi.org/10.1016/j.apm.2015.04.030>
- [4] Virally SJ, Reed CP, Thomas JA, *et al.* Automatic downlink system. United States patent US 7380616. 2008.
- [5] Scherbatskoy SA. Method and apparatus for communicating between spaced locations in a borehole. United States patent US 5113379. 1992.
- [6] Parkin EG, Bogath CC. Continuous Downlinking While Drilling. United States patent US 14/945549. 2015.
- [7] Sugiura J. Downlinking communication system and method. United States patent US 8570833. 2013.
- [8] Sugiura J. Downlinking communication system and method using signal transition detection. United States patent US 8792304. 2014.
- [9] Finke MD, Warren IADR, Sun C, *et al.* Downlink telemetry system. United States patent US 6920085. 2005.
- [10] Moriarty KA. Rotary downlink system. United States patent US 7298285. 2007.
- [11] Treviranus J, Doerge H, Kurella M. Method and apparatus for downlink communication. United States patent US 7518950. 2009.
- [12] Winnacker H, Draeger U. Controllable pressure-reducing valve and device for the generation of pressure change signals. United States patent US 8042572. 2011.

Received on 14-10-2023

Accepted on 20-11-2023

Published on 30-11-2023

DOI: <https://doi.org/10.31875/2409-9694.2023.10.07>© 2023 Wu *et al.*; Licensee Zeal Press.

This is an open access article licensed under the terms of the Creative Commons Attribution Non-Commercial License (<http://creativecommons.org/licenses/by-nc/3.0/>), which permits unrestricted, non-commercial use, distribution and reproduction in any medium, provided the work is properly cited.